

FRONTAL (1 : 10)

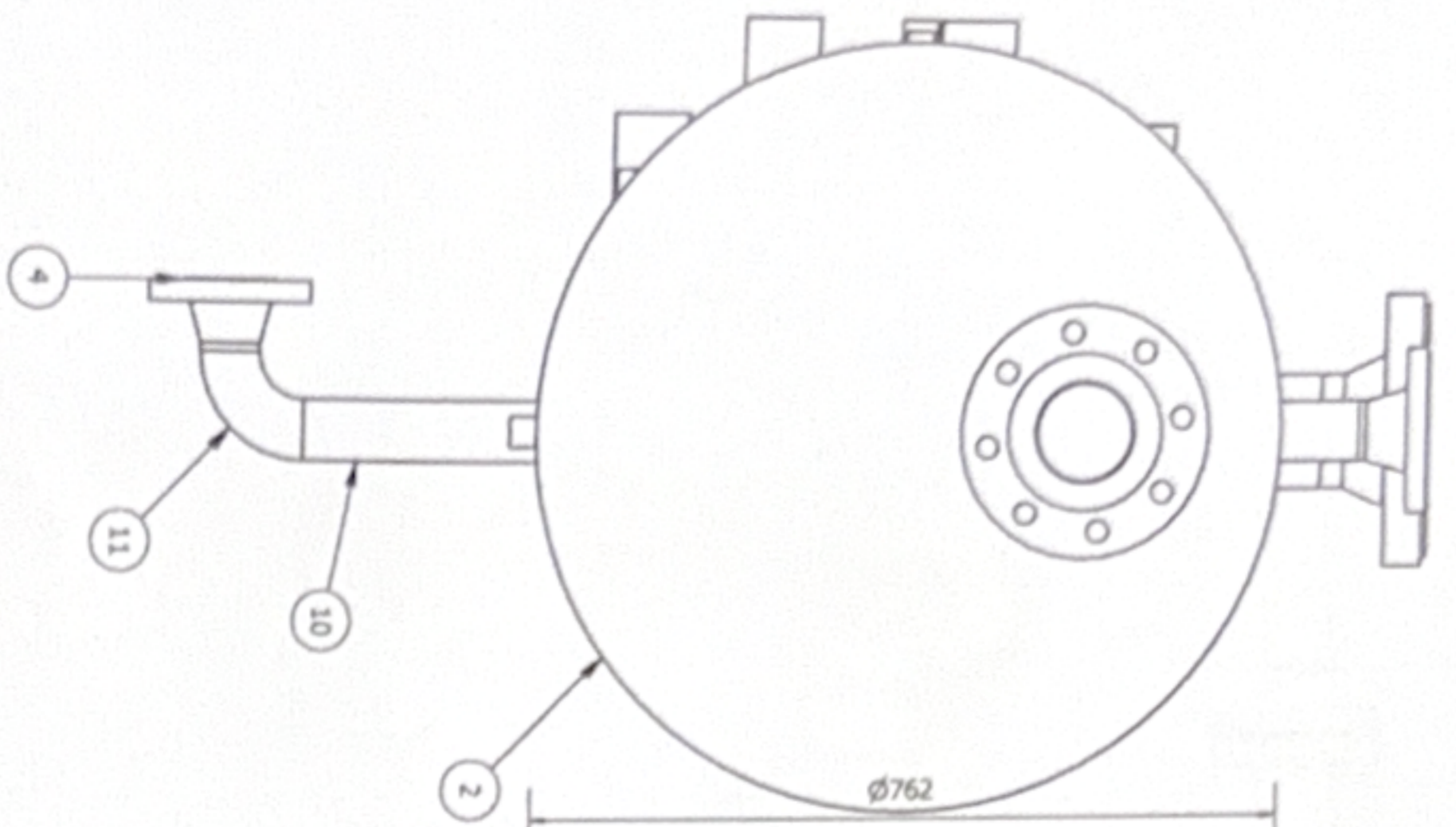

LATERAL (1 : 10)

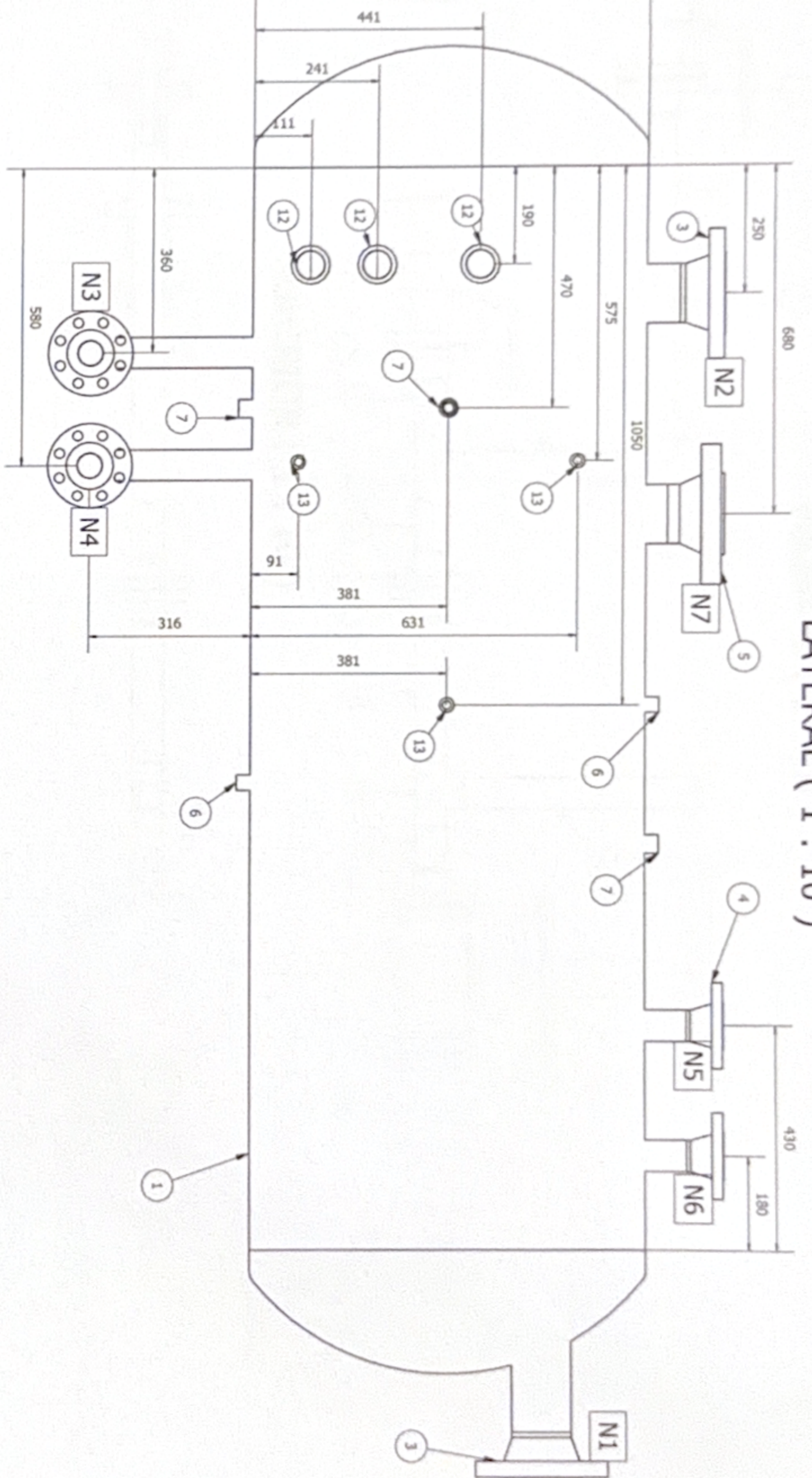

PARTS LIST

ITEM QTY	ITEM	UNIT	QTY	PART NUMBER
1	1	1	1	Envolvente 30" x 5/8"
2	2	1	1	Casquete 30" x 5/8"
2	3	1	1	ASME B16.5 Flange Welding Neck - Class 300 4
4	4	1	1	ASME B16.5 Flange Welding Neck - Class 300 2
2	5	1	1	ASME B16.5 Flange Welding Neck - Class 600 4
2	6	1	1	ASME B16.11 Half Coupling - Class 3000 1/2
3	7	1	1	ASME B16.11 Half Coupling - Class 3000 3/4
2	8	3,937 in	1	ASME B36.10M Pipe 4 - Schedule 80 - 3,9370079
2	9	7,874 in	1	ASME B36.10M Pipe 2 - Schedule 80 - 7,8740157
2	10	9,843 in	1	ASME B36.10M Pipe 2 - Schedule 80 - 9,8425197
2	11	1	1	ASME B16.9 Long Radius 90 Deg Elbow 2 x 0.218
3	12	1	1	ASME B16.11 Coupling Threaded - Class 3000 2 x 2
3	13	1	1	ASME B16.11 Half Coupling Threaded - Class 3000 1/2 x 1/2
1	14	1	1	ASME B16.9 Straight Tee 4 x 0.337
1	15	15,748 in	1	ASME B36.10M Pipe 4 - Schedule 80 - 15,748031

IT	DESCRIPCIÓN
N1	ENTRADA
N2	SALIDA DE GAS
N3	SALIDA DE PETRÓLEO
N4	SALIDA DE AGUA
N5	VÁLVULA DE SEGURIDAD
N6	DISCO DE RUPTURA
N7	CONTROLADOR DE NIVEL

Dibujó: FA Alvarez
 Fecha: 14/07/2019
 Descripción: Vessel

Material:
 Revisión:
 Peso: 883,9 kg

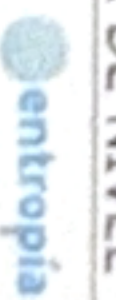

FRONTAL (1 : 10)

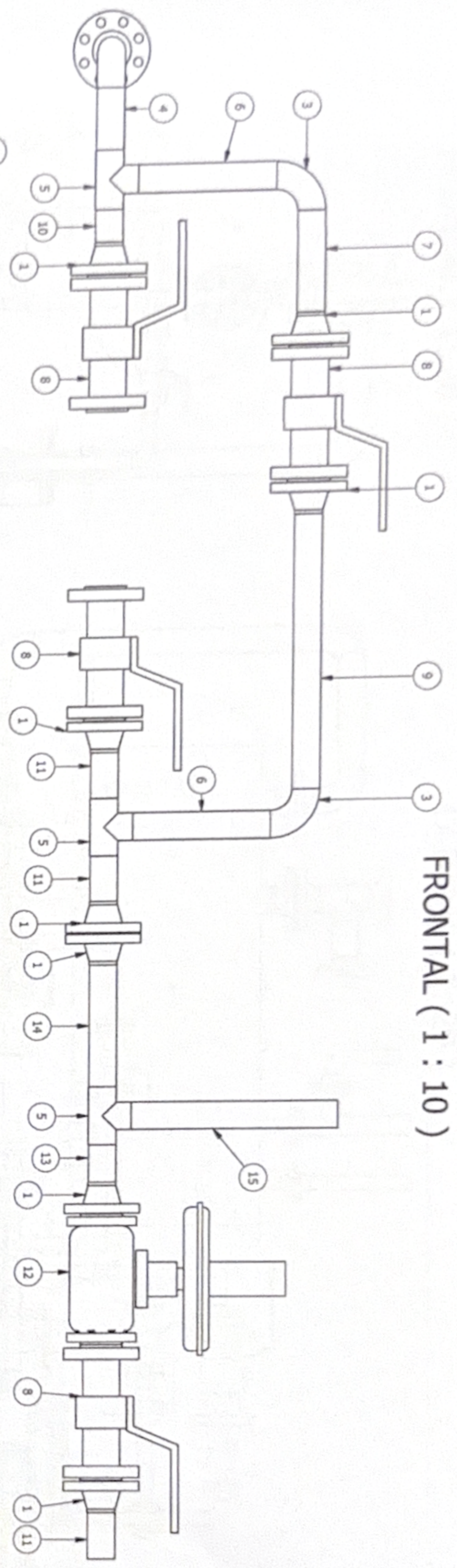

SUPERIOR (1 : 10)

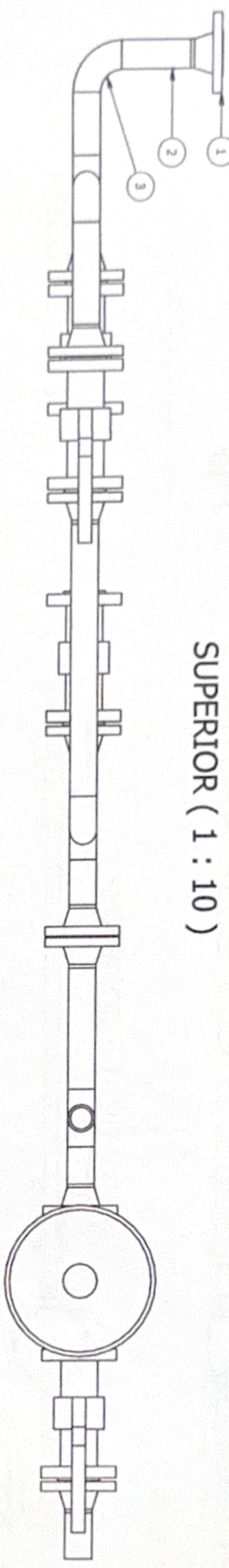

PARTS LIST

ITEM	ITEM QTY	UNIT	QTY	PART NUMBER	ITEM	ITEM QTY	UNIT	QTY	PART NUMBER
7	1	8,661 in		ASME B36.10M Pipe 2 - Schedule 80 - 8,6614173	1	9	1		ASME B16.5 Flange Welding Neck - Class 300 2
9	1	23,622 in		ASME B36.10M Pipe 2 - Schedule 80 - 23,622047	3	3	1		ASME B16.9 Long Radius 90 Deg Elbow 2 x 0.218
6	2	11,811 in		ASME B36.10M Pipe 2 - Schedule 80 - 11,811024	4	1	5,118 in		ASME B36.10M Pipe 2 - Schedule 80 - 5,1181102
10	1	2,756 in		ASME B36.10M Pipe 2 - Schedule 80 - 2,7559055	5	3	1		ASME B16.9 Straight Tee 2 x 0.218
11	3	3,937 in		ASME B36.10M Pipe 2 - Schedule 80 - 3,9370079	8	4	1		Válvula Esférica 2" #300
13	1	3,228 in		ASME B36.10M Pipe 2 - Schedule 80 - 3,2283465	12	1	1		Válvula de Control
14	1	10,551 in		ASME B36.10M Pipe 2 - Schedule 80 - 10,551181	15	1	17,677 in		ASME B36.10M Pipe 2 - Schedule 80 - 17,677165
					2	1	5,906 in		ASME B36.10M Pipe 2 - Schedule 80 - 5,9055118

PARTS LIST

ITEM	ITEM QTY	UNIT	QTY	PART NUMBER
1	1	10,551 in		ASME B36.10M Pipe 2 - Schedule 80 - 10,551181

Dibujó: Fecha: Aprobó: Fecha:

FAVAREZ 14/07/2019
 Descripción: Línea de Agua
 Material: Revisión: Peso 199,2 kg

FRONTAL (1 : 20)

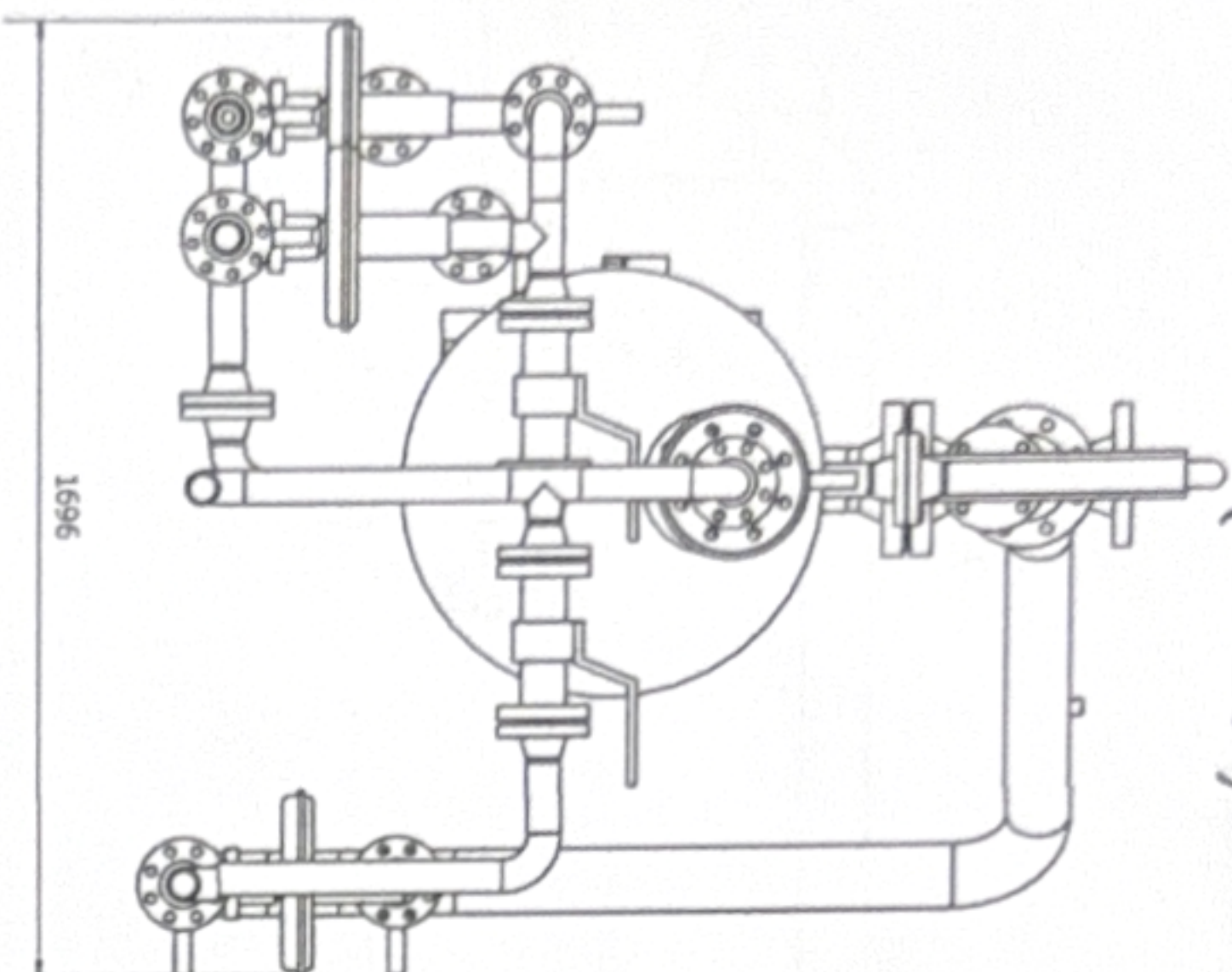

LATERAL (1 : 20)

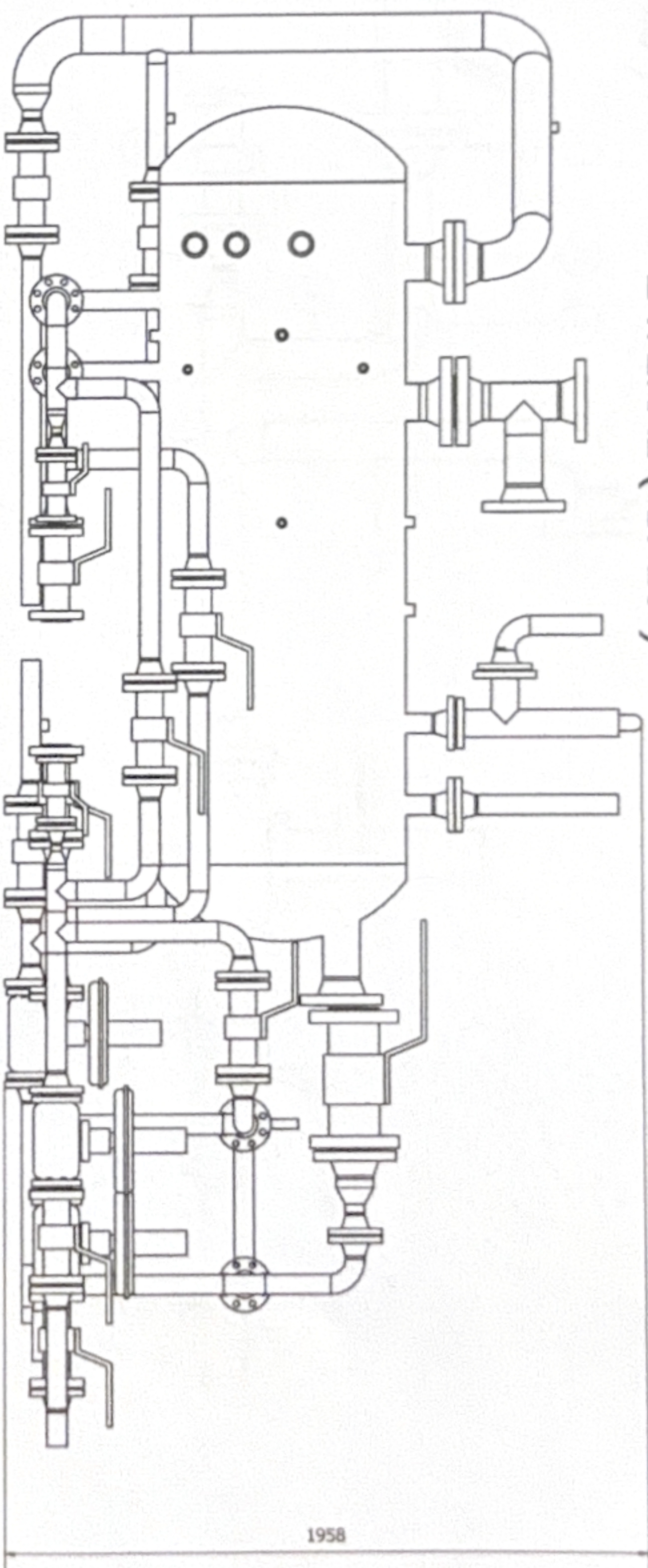

ISOMÉTRICO (1 : 30)

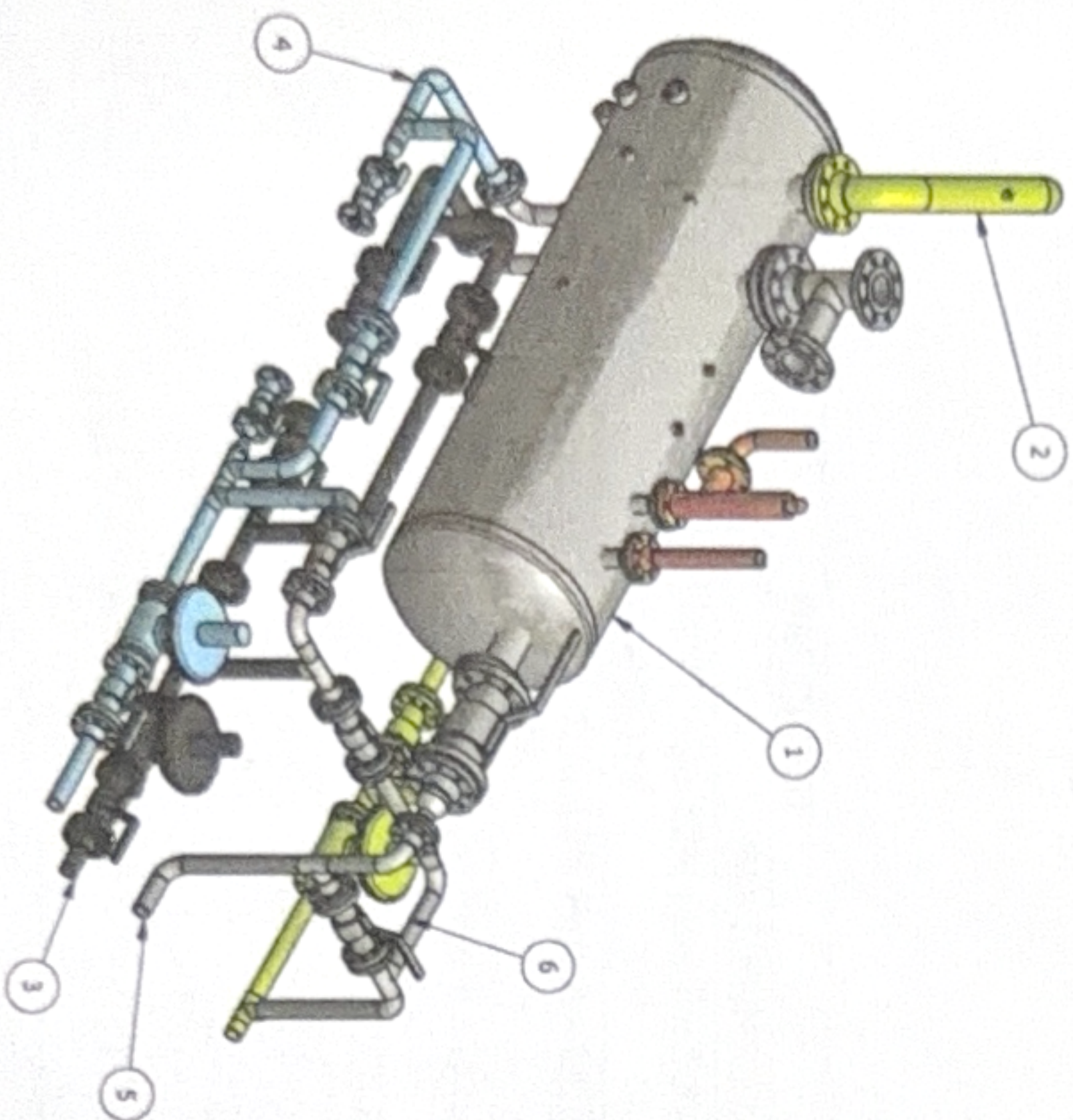

SUPERIOR (1 : 20)

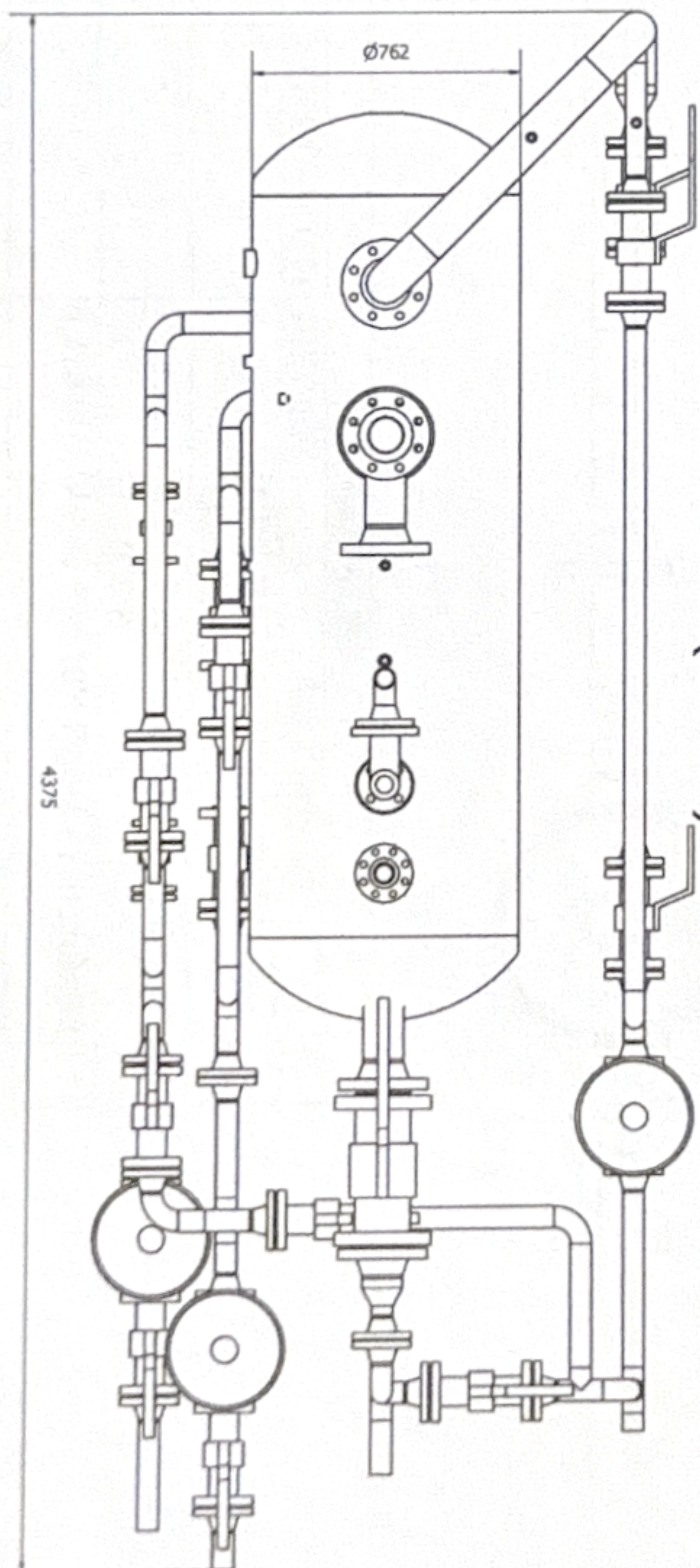

PARTS LIST			PARTS LIST		
ITEM	QTY	PART NUMBER	ITEM	QTY	PART NUMBER
1	1	Vessel	4	1	Línea de Petróleo
2	1	Línea de Gas	5	1	Línea de Entrada
3	1	Línea de Agua	6	1	Línea de By Pass

Dibujó: Fecha:
 FANvarez 14/07/2019 Aprobó:
 Descripción: Fecha:
 Separador S030A Revisión:



Material: Peso
1764 Kg

FRONTAL (1 : 10)

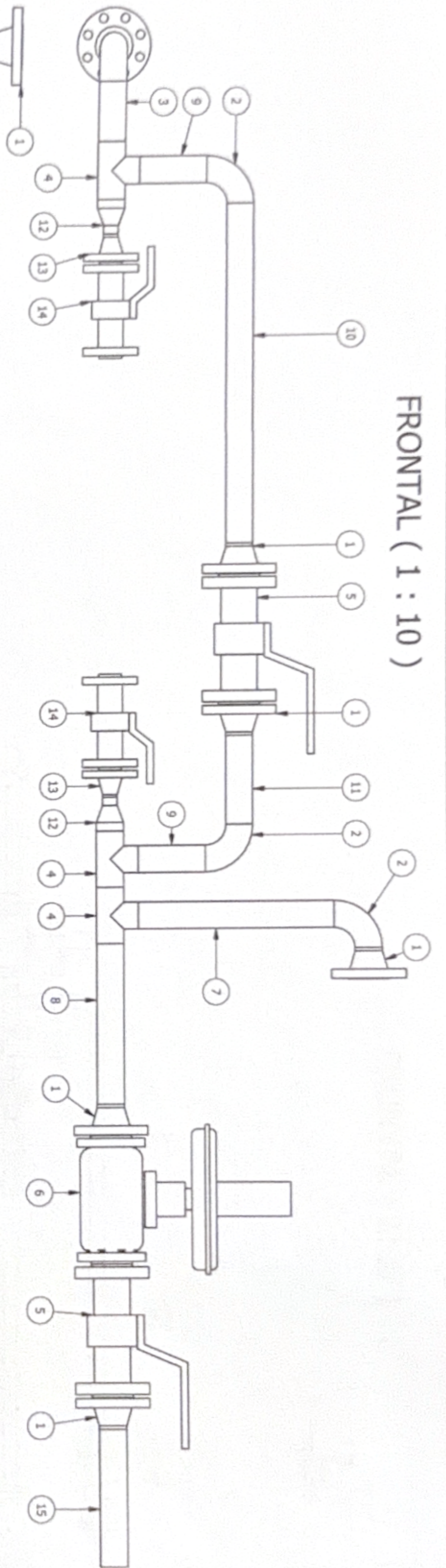

SUPERIOR (1 : 10)

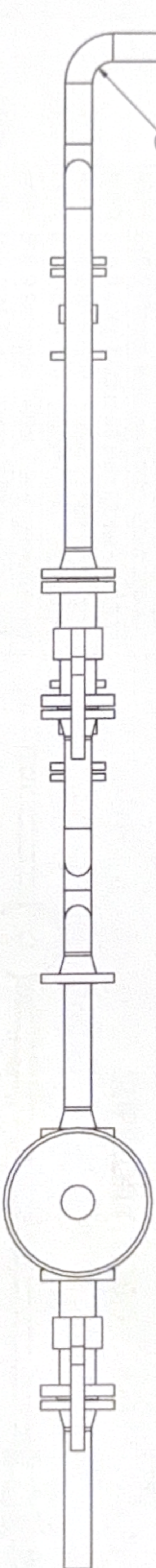

PARTS LIST

ITEM	ITEM QTY	UNIT QTY	PART NUMBER	ITEM	ITEM QTY	UNIT QTY	PART NUMBER
9	2	5,906 in	ASME B36.10M Pipe 2 - Schedule 80 - 5,9055118	1	6	1	ASME B16.5 Flange Welding Neck - Class 300 2
10	1	29,921 in	ASME B36.10M Pipe 2 - Schedule 80 - 29,92126	2	4	1	ASME B16.9 Long Radius 90 Deg Elbow 2 x 0.218
11	1	7,874 in	ASME B36.10M Pipe 2 - Schedule 80 - 7,8740157	3	1	5,118 in	ASME B36.10M Pipe 2 - Schedule 80 - 5,1181102
12	2	1	ASME B16.9 Reducer 2 - Schedule 80	4	3	1	ASME B16.9 Straight Tee 2 x 0.218
13	2	1	ASME B16.5 Flange Welding Neck - Class 300 1	5	2	1	Válvula Esférica 2" #300
14	2	1	Válvula Esférica 1" #300	6	1	1	Válvula de Control
15	1	11,811 in	ASME B36.10M Pipe 2 - Schedule 80 - 11,811024	7	1	17,165 in	ASME B36.10M Pipe 2 - Schedule 80 - 17,165354
				8	2	14,173 in	ASME B36.10M Pipe 2 - Schedule 80 - 10,23622

PARTS LIST

ITEM	ITEM QTY	UNIT QTY	PART NUMBER
8	2	14,173 in	ASME B36.10M Pipe 2 - Schedule 80 - 10,23622

Dibujó: Fecha: Aprobó: Fecha:

FAVarez 14/07/2019

Descripción: Línea de Petróleo

Material: Revisión: Peso N/A

ITEM	QTY	UNIT	QTY	PART NUMBER
1	1	1		ASME B16.5 Flange Welding Neck - Class 300 4
2	3	1		ASME B16.9 Long Radius 90 Deg Elbow 4 x 0.337
3	1	27,559 in		ASME B36.10M Pipe 4 - Schedule 80 - 27,559055
4	1	35,433 in		ASME B36.10M Pipe 4 - Schedule 80 - 35,433071
5	1	1		ASME B16.9 Reducing Outlet Tee 4 - Schedule 80
6	1	5,118 in		ASME B36.10M Pipe 4 - Schedule 80 - 5,1181102
7	1	12,598 in		ASME B36.10M Pipe 2 - Schedule 80 - 12,598425
8	3	1		Válvula Esférica #300
9	8	1		ASME B16.5 Flange Welding Neck - Class 300 2
10	1	1		ASME B16.9 Reducer 4 - Schedule 80
11	1	42,126 in		ASME B36.10M Pipe 2 - Schedule 80 - 42,125984
12	1	14,567 in		ASME B36.10M Pipe 2 - Schedule 80 - 14,566929
13	2	1		ASME B16.9 Straight Tee 2 x 0.218
14	1	9,724 in		ASME B36.10M Pipe 2 - Schedule 80 - 9,7244094
15	1	1		ASME B16.9 Long Radius 90 Deg Elbow 2 x 0.218
16	1	73,937 in		ASME B36.10M Pipe 2 - Schedule 80 - 73,937008
17	1	1		Válvula de Control
18	1	1,969 in		ASME B36.10M Pipe 2 - Schedule 80 - 1,9685039
19	2	1		ASME B16.11 Half Coupling Threaded - Class 3000 1/2 x 1/2
20	1	1		ASME B16.11 Half Coupling Threaded - Class 3000 3/4 x 3/4
21	1	19,173 in		ASME B36.10M Pipe 2 - Schedule 80 - 19,173228

PARTS LIST

FRONTAL (1:20)

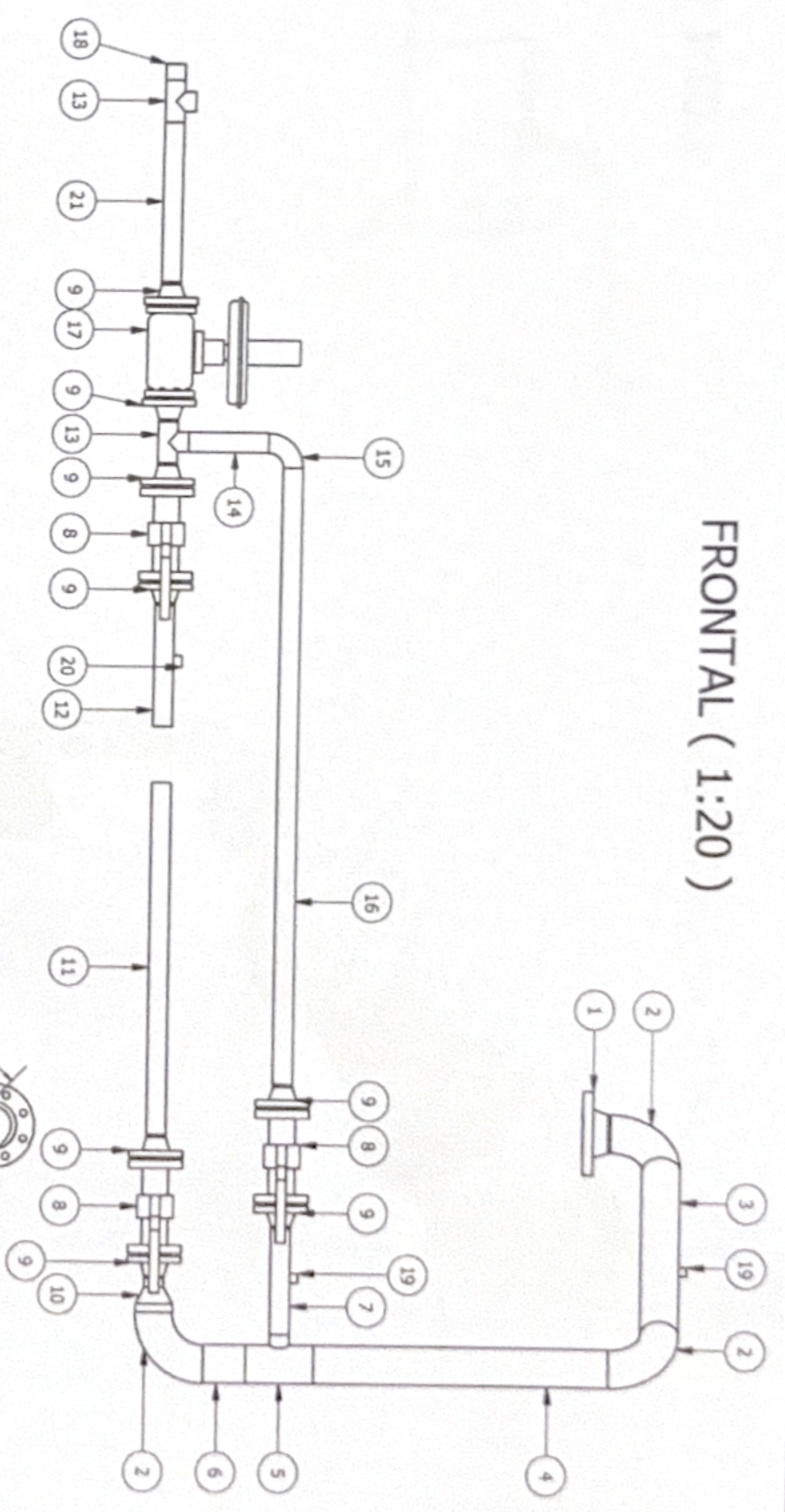

SUPRIOR (1:20)

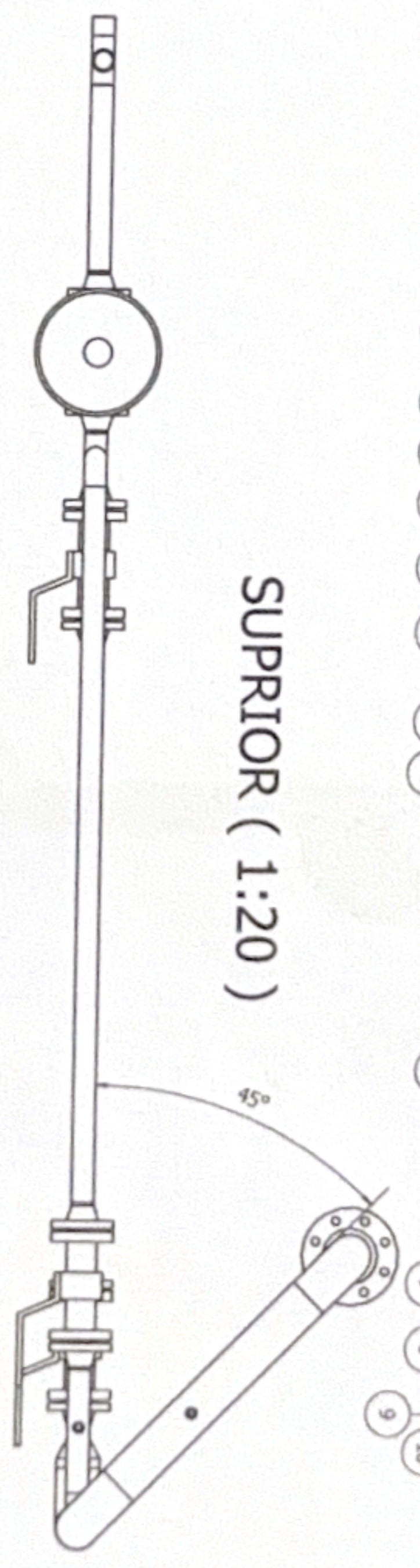

ISOMÉTRICA (1:30)

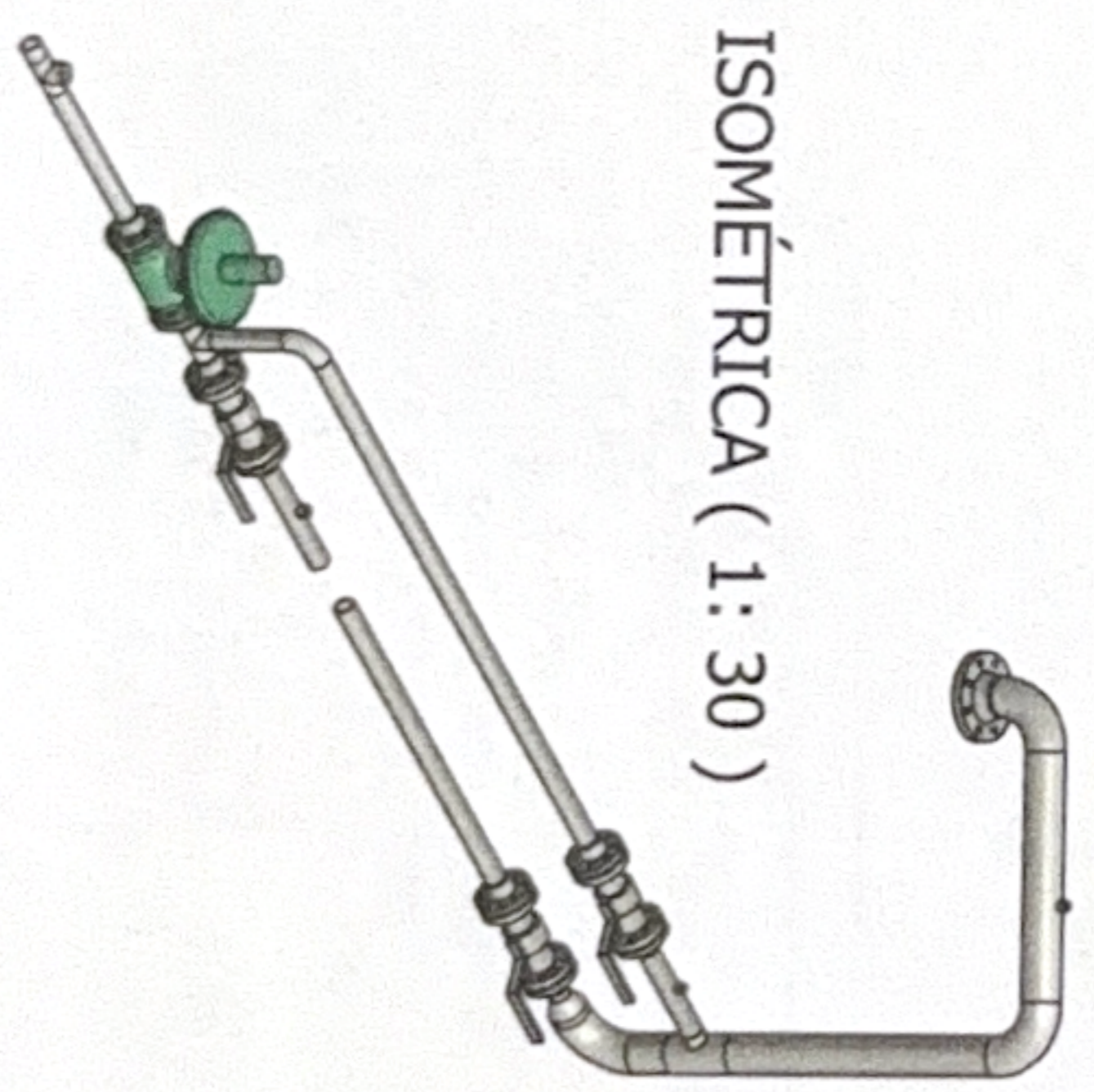

Dibujó:	Fecha:	Aprobó:	Fecha:
FAlvarez 14/07/2019			
Descripción: Línea de Gas			
Materia:	Revisión	Peso	
		N/A	



FRONTAL (1:10)

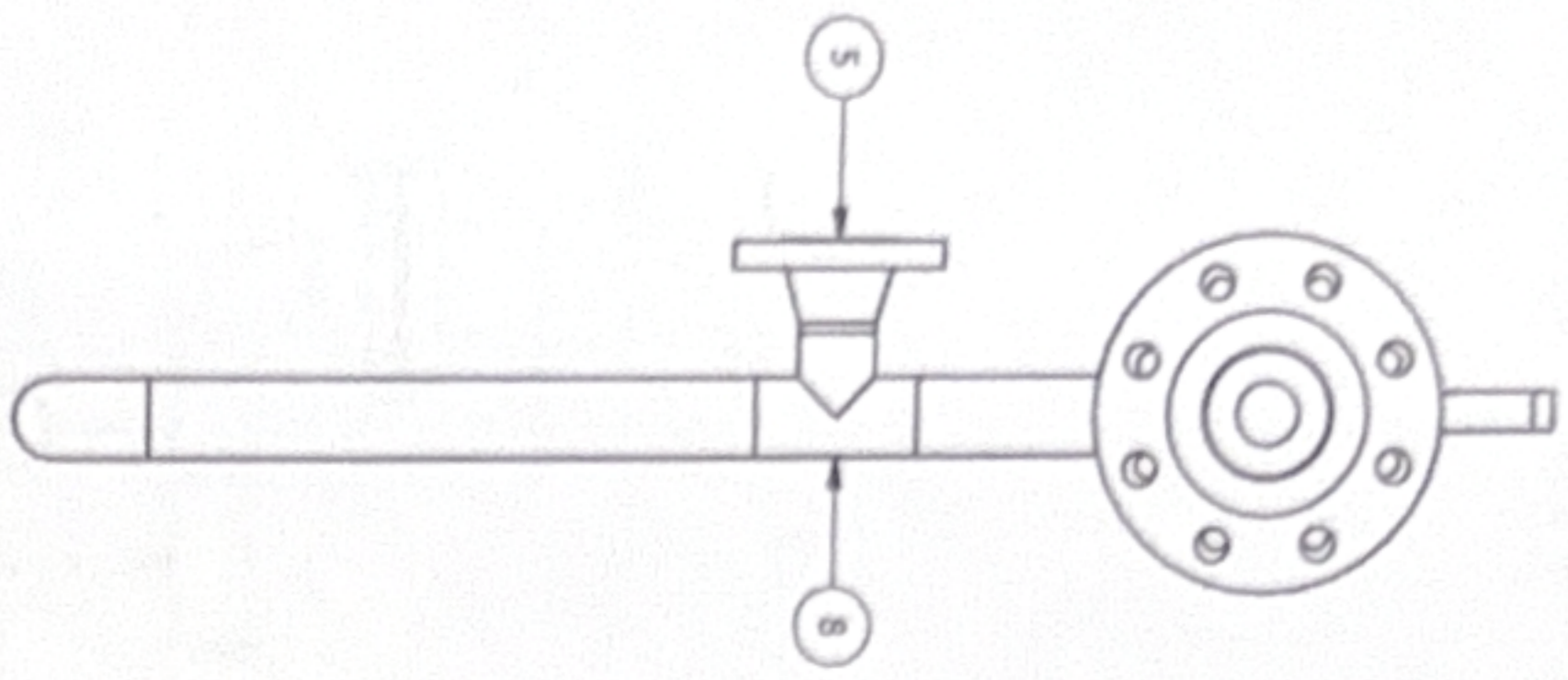

LATERAL (1:10)

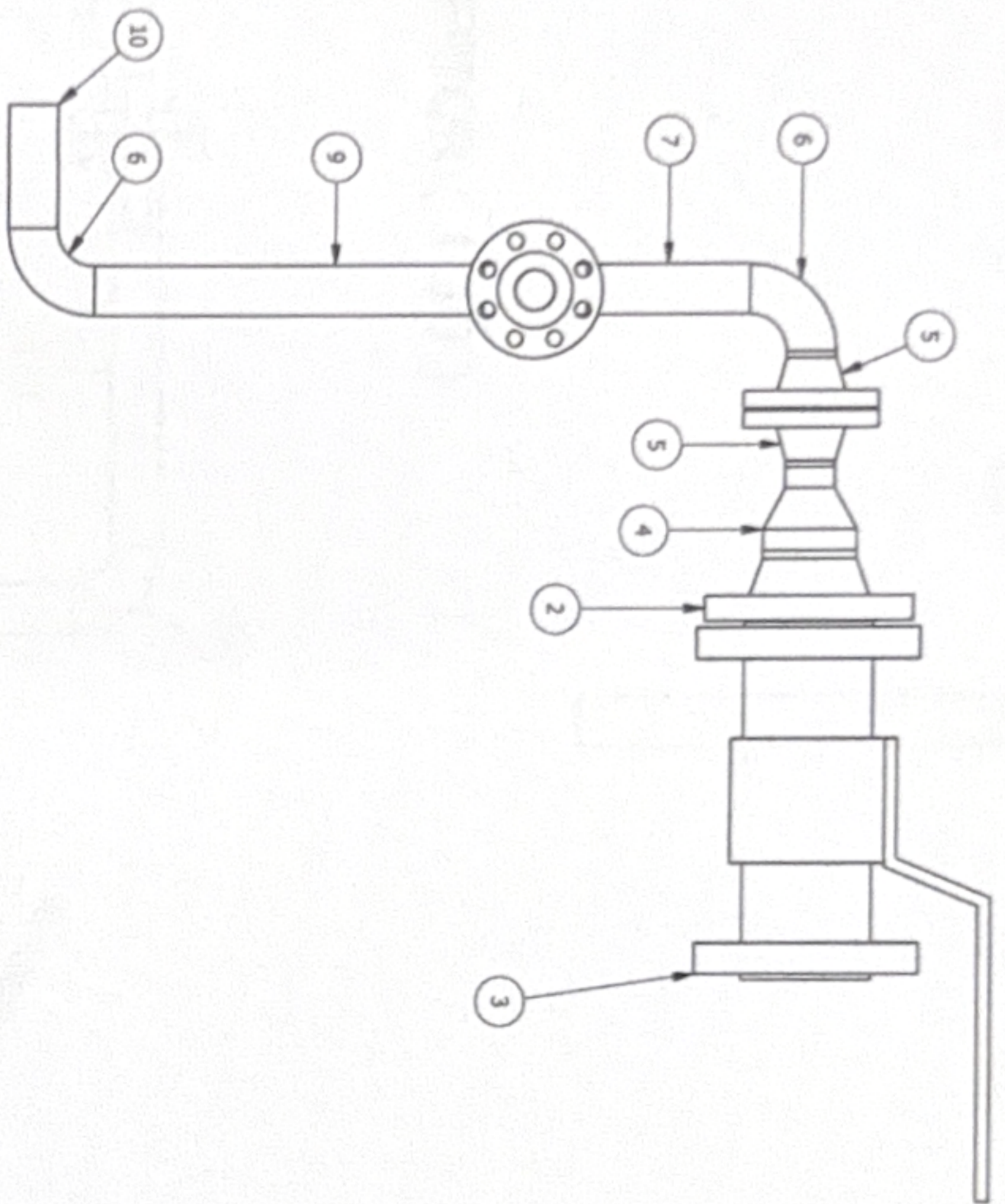

ISOMÉTRICA (1:10)

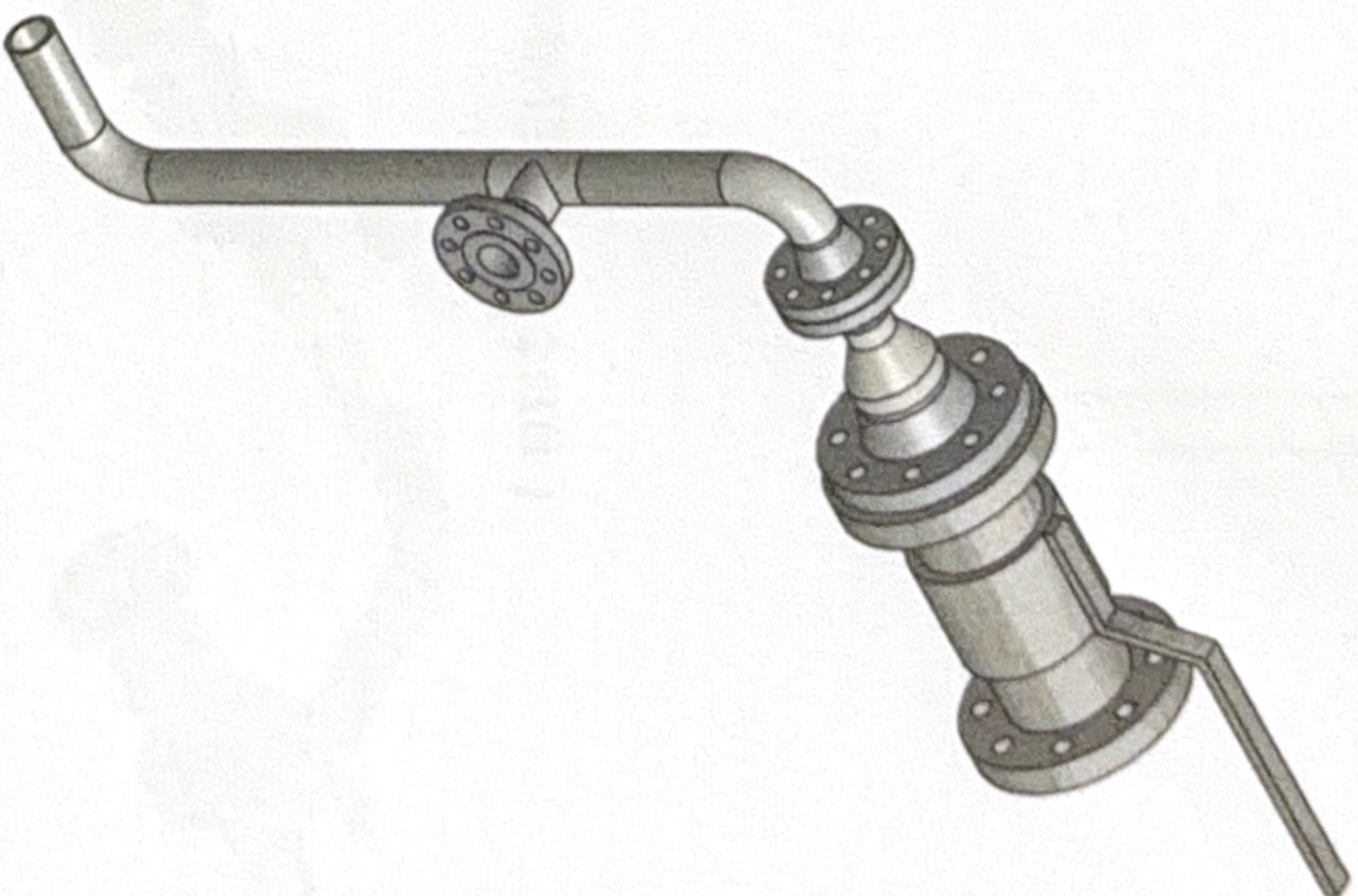

PARTS LIST

ITEM	ITEM QTY	UNIT QTY	PART NUMBER
2	1	1	ASME B16.5 Flange Welding Neck - Class 300 4
3	1	1	VÁLVULA ESFÉRICA 4"
4	1	1	ASME B16.9 Reducer 4 - Schedule 80
5	3	1	ASME B16.5 Flange Welding Neck - Class 300 2
6	2	1	ASME B16.9 Long Radius 90 Deg Elbow 2 x 0.218
7	1	1	ASME B36.10M Pipe 2 - Schedule 80 - 7,8740157
8	1	1	ASME B16.9 Straight Tee 2 x 0.218
9	1	1	ASME B36.10M Pipe 2 - Schedule 80 - 18,897638
10	1	5,906 in	ASME B36.10M Pipe 2 - Schedule 80 - 5,9055118

Dibujó: Fecha:
 FAlvarez 14/07/2019
 Descripción: Aprobó:
 Línea de Entrada Fecha:



Material: Revisión:
 N/A Peso:

FRONTAL (1:10)

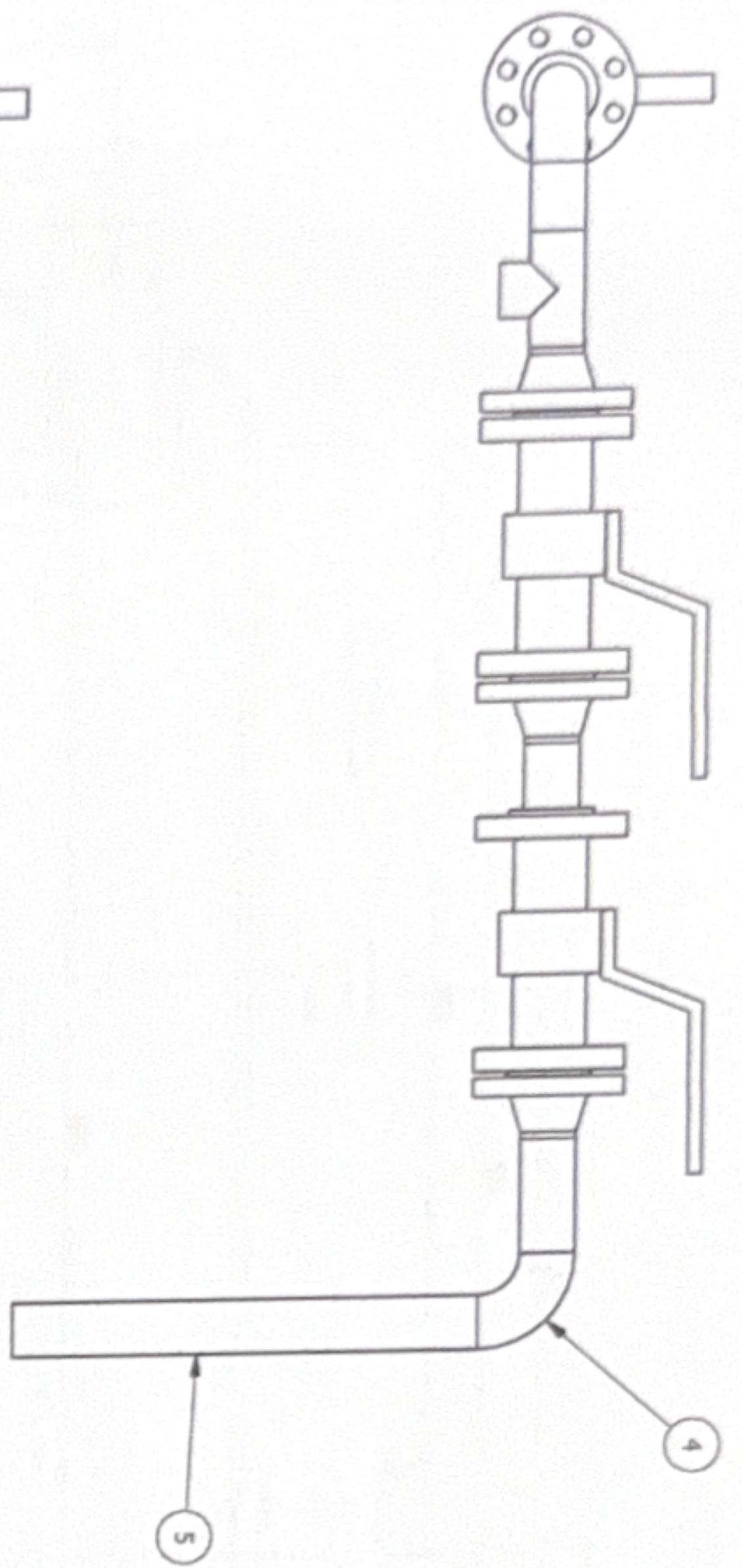

LATERAL (1:10)

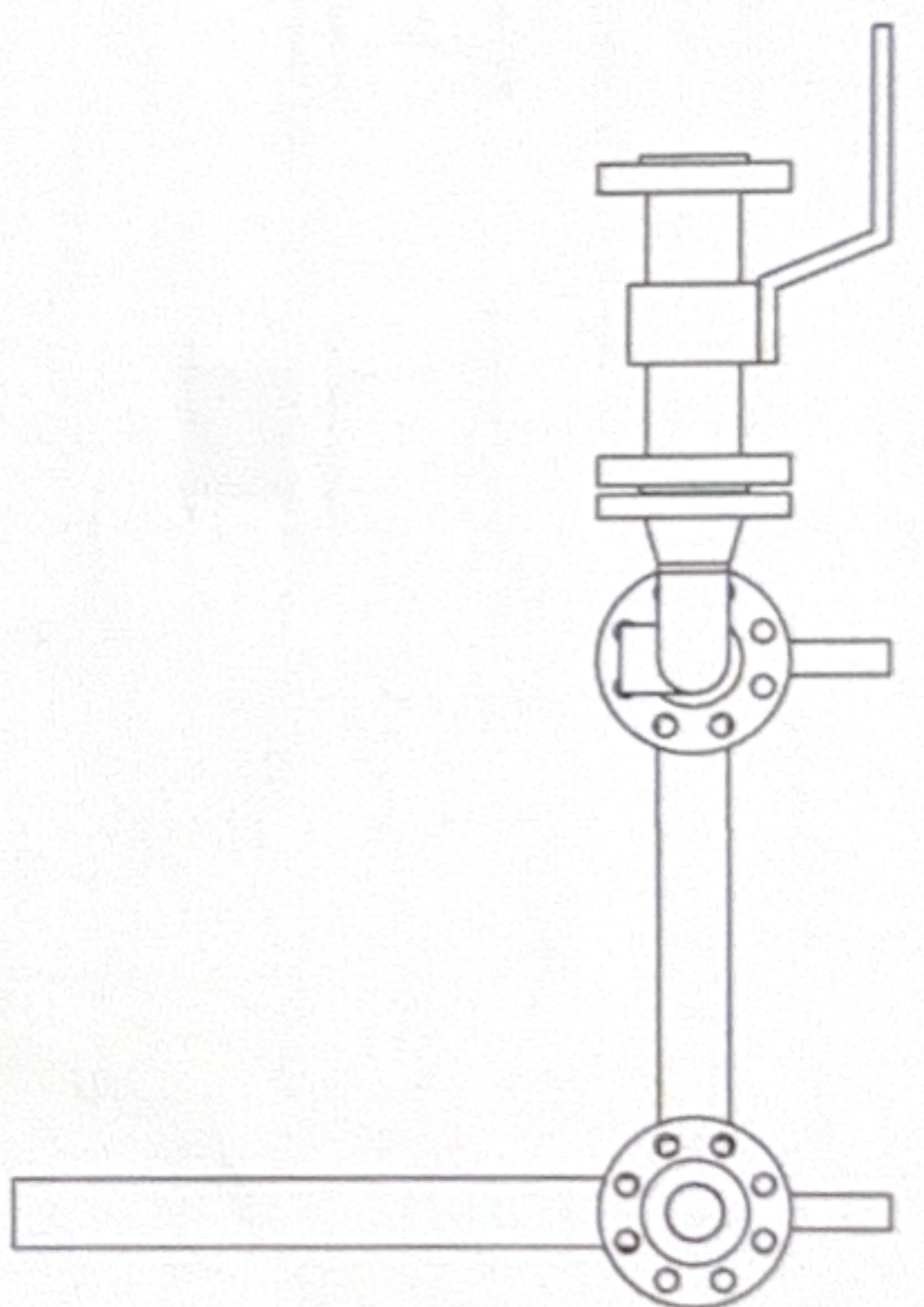

SUPERIOR (1:10)

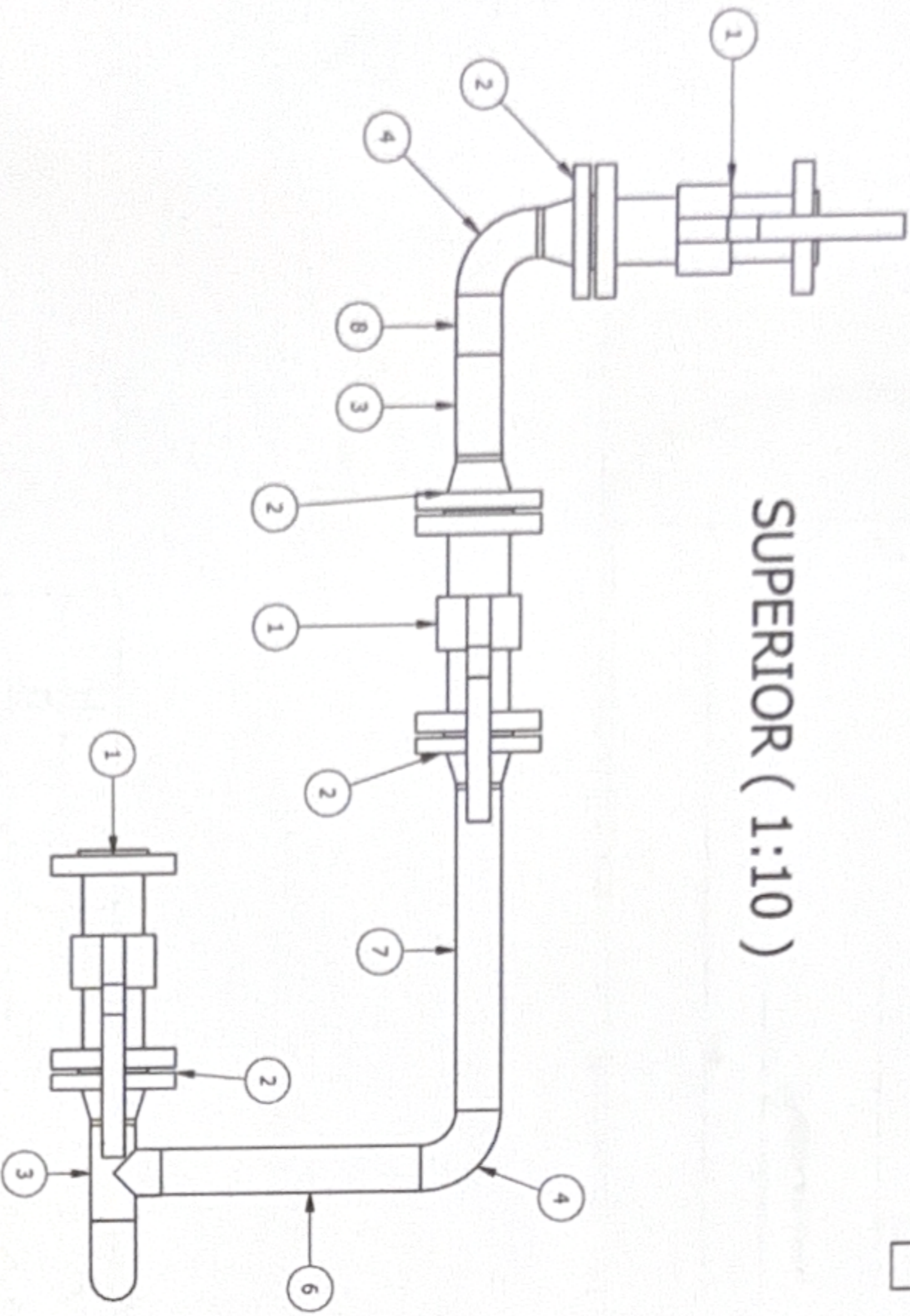

ISOMÉTRICA (1:10)

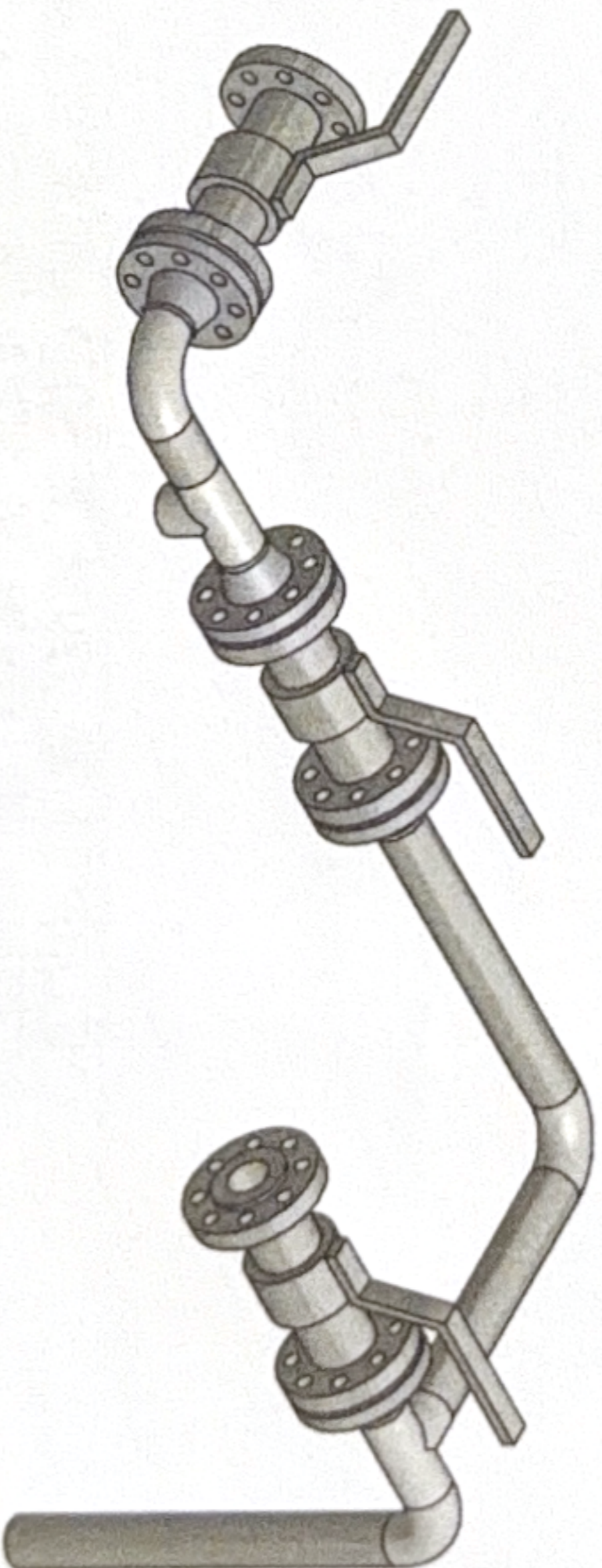

PARTS LIST

ITEM	ITEM QTY	UNIT QTY	PART NUMBER
1	3	1	Válvula Esférica 2" #300
2	4	1	ASME B16.5 Flange Welding Neck - Class 300 2
3	2	1	ASME B16.9 Straight Tee 2 x 0.218
4	3	1	ASME B16.9 Long Radius 90 Deg Elbow 2 x 0.218
5	1	20,236 in	ASME B36.10M Pipe 2 - Schedule 80 - 20,23622
6	1	13,583 in	ASME B36.10M Pipe 2 - Schedule 80 - 13,582677
7	1	16,732 in	ASME B36.10M Pipe 2 - Schedule 80 - 16,732283
8	1	2,953 in	ASME B36.10M Pipe 2 - Schedule 80 - 2,9527559

Dibujó: Fecha: 14/07/2019
 Fecha: Aprobó:
 Descripción: Fecha:
 Línea de By Pass

Materiál: Revisión:
 Peso: 79,5 kg



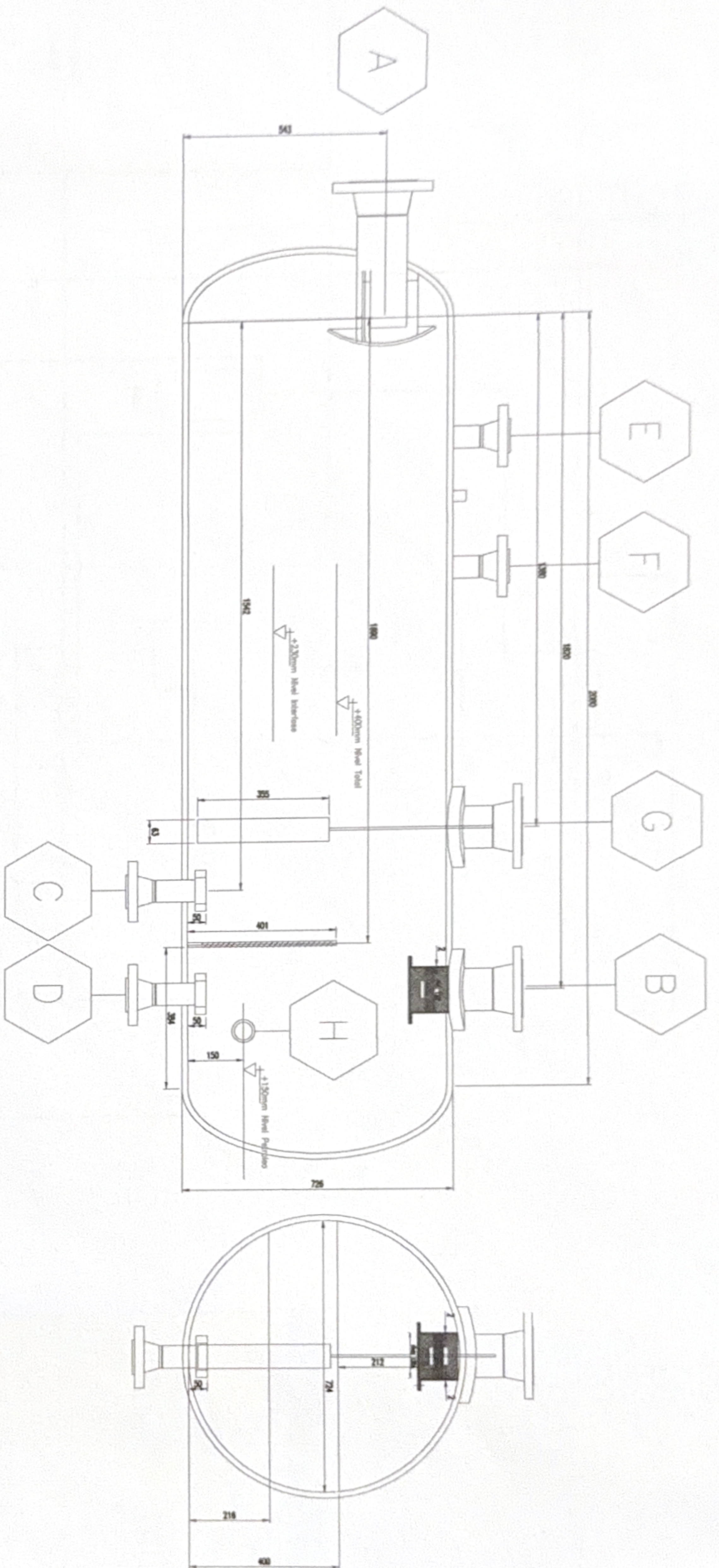

CONEXION	CANT.	∅	TIPO	SERIE	SERVICIO
H	1	2"	CUPLA	6000#	CONTROLADOR DE NIVEL DE PETROLEO
G	1	4"	WNRF	600#	CONTROLADOR DE NIVEL DE INTERFASE
F	1	2"	WNRF	600#	VALVULA DE SEGURIDAD
E	1	2"	WNRF	600#	PLACA ESTALLIDO
D	1	2"	WNRF	600#	SALIDA DE PETROLEO
C	1	2"	WNRF	600#	SALIDA DE AGUA
B	1	4"	WNRF	600#	SALIDA DE GAS
A	1	4"	WNRF	600#	ENTRADA DE FLUIDO

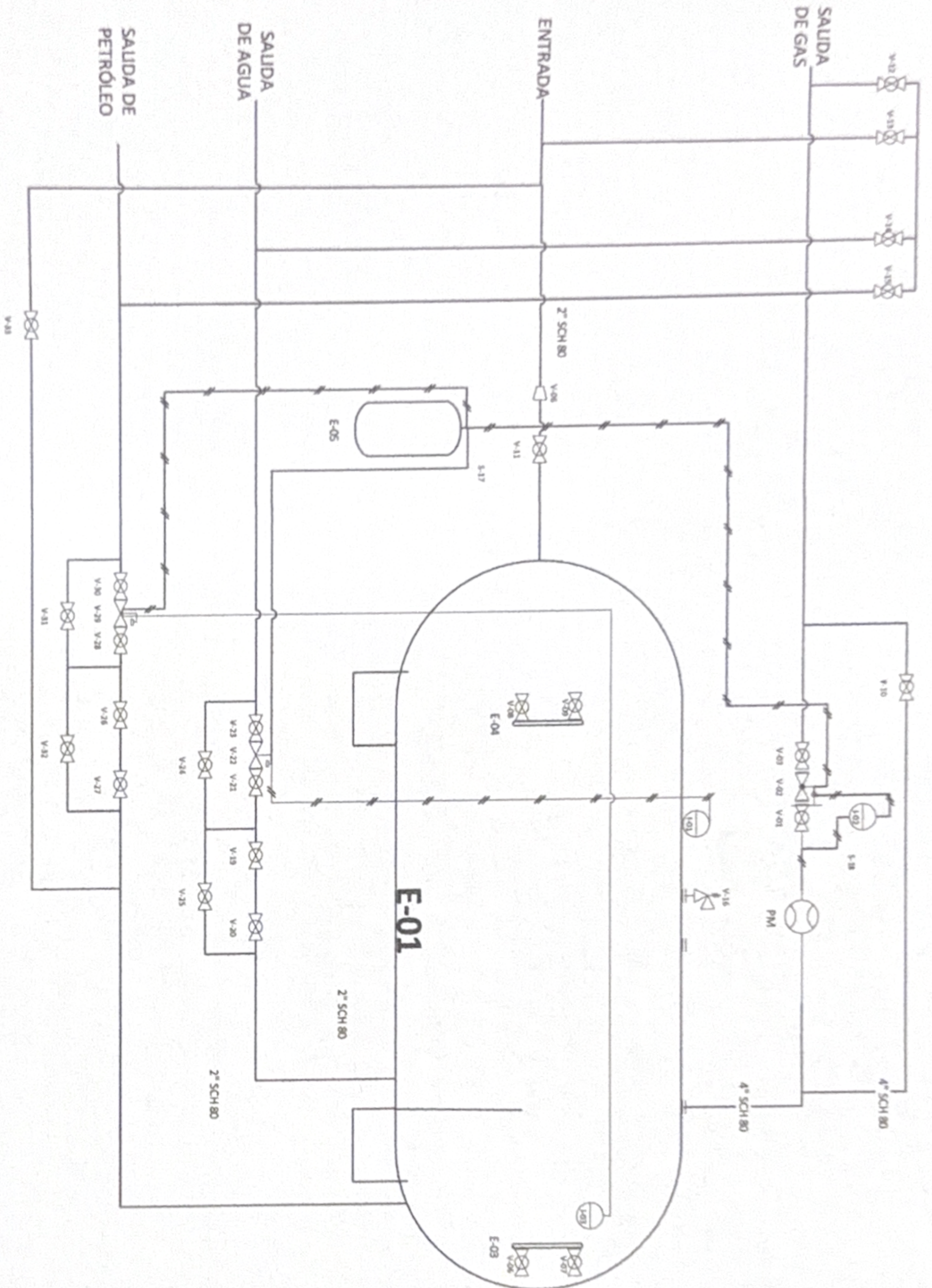

Lista de válvulas

Texto mostrado	Descripción
V-01	Válvula Esférica #3000
V-02	Válvula de Control de Presión
V-03	Válvula Esférica #3000
V-05	Reducción 4"x6"
V-06	Reducción 4"x5"
V-07	Válvula Esférica 1/2" #3000
V-08	Válvula Esférica 3/4" #3000
V-09	Válvula Esférica 3/4" #3000
V-10	Válvula Esférica 2" #3000
V-11	Válvula Esférica 2" #3000
V-12	Válvula Esférica 2" #3000
V-13	Válvula Esférica 2" #3000
V-14	Válvula Esférica 2" #3000
V-15	Válvula Esférica 2" #3000
V-16	Válvula de Seguridad - Set 1.512 psi
V-19	Válvula Esférica 2" #3000
V-20	Válvula Esférica 2" #3000
V-21	Válvula Esférica 2" #3000
V-22	Válvula de Control de Agua
V-23	Válvula Esférica 2" #3000
V-24	Válvula Esférica 2" #3000
V-25	Válvula Esférica 2" #3000
V-26	Válvula Esférica 2" #3000
V-27	Válvula Esférica 2" #3000
V-28	Válvula Esférica 2" #3000
V-29	Válvula de Control de Oil
V-30	Válvula Esférica 2" #3000
V-31	Válvula Esférica 2" #3000
V-32	Válvula Esférica 2" #3000
V-33	Válvula Esférica 2" #3000

Lista de equipamiento

Texto mostrado	Descripción
E-01	Separador S017A
E-03	Visor de Nivel
E-04	Visor de Nivel
E-05	Pulmón de Instrumentos

Lista de instrumentos

Texto mostrado	Descripción
I-01	Control de Nivel de Interfase
I-02	Controladora de Válvula de Gas
I-03	Control de Nivel Total



OMEGA

Facundo Alvarez

EMITIDO

EMITIDO

TAMAÑO

A3

FECHA

05/08/19

TÍTULO

REX

ESCALA

N/A

PLANO SEPARADOR S017A

01

NOVA

1 DE 1